

Pingel[®] Electric Speed Shifter Kit for 2006-2014 Kawasaki ZX14

Designed for Street Use

#77102 Installation Instructions

Read all instructions thoroughly, look at photos and all components before attempting installation. This product is not designed or intended to be used as an assistive device for any particular disability.

All the components of this Electric Speed Shifter Kit have been assembled and tested as a unit before leaving our factory and have been found to be in working order at the time of shipping. Installation of this kit requires detailed knowledge of the motorcycle model, its electronics and mechanics. It is assumed that the installer has access to the proper tools and a working knowledge of them, test equipment (such as a voltmeter), and factory service manuals. The following instructions must be read in their entirety and any questions should be answered prior to attempting installation. Incorrect installation will result in damage to Electric Speed Shifter components. If after reading the instructions you do not feel comfortable installing the kit, please find a qualified technician to do the installation. Installation time is 2-3 hours.

Disconnect negative battery cable before attempting any work on motorcycle.

INSTALLATION OF DUAL BUTTON HANDLEBAR CONTROL BRACKET:

Loosen the clutch master cylinder perch and slide it toward the fork 7/16". Retighten the clutch master cylinder perch. Measure from the newly positioned clutch master cylinder perch to the turn signal switch housing and record this length. Disassemble the turn signal switch housing. Inside of the turn signal housing there is a raised portion in the housing that fits into a hole in the handlebar. Using the length recorded earlier, measure from the original hole towards the turn signal switch housing and mark the location for a new hole. Drill the hole the same diameter as the original (center punching the mark will help keep the drill bit in position). Reassemble the turn signal switch housing at the newly drilled location, see figure 1.

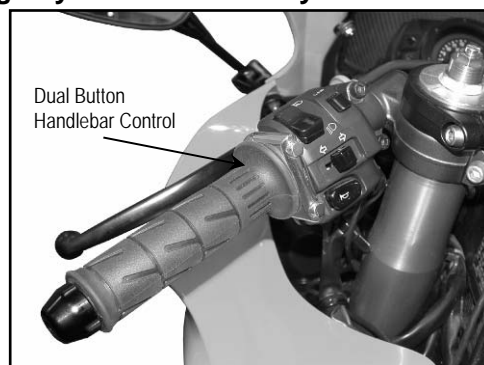

Figure 1

Install the dual button handlebar control bracket onto the handlebar as close to the switch housing as possible, making sure to tuck the wires neatly into the grooved channel of the bracket. Covering this area with tape will hold the wires and help insure they don't get pinched. Make sure the tape isn't put in a visible area.

Route the wires from the dual button control neatly along handlebar and under the fuel tank following the clutch line (or inside the handlebar to under the fuel tank, see the following paragraph). Secure wires along their route with the wire ties provided. Loosening and lifting the fuel tank will aid in wire routing. The final location of this wire assembly will be in the battery compartment, see figure 2.

If this handlebar control bracket is being installed on a custom motorcycle, the wires can be hidden inside the handlebars. This is accomplished by feeding the black cable through the hole in the bottom of the bracket and then through a hole in the handlebars. Use caution and protect the wires (shrink wrap) where they pass any sharp edges, such as the handlebar hole.

INSTALLATION OF CONTROL MODULE AND WIRE HARNESS:

The mounting location for the control module is in the battery compartment. The control module is supplied with Velcro to secure it. The handlebar connector has 4 pins and should be connected to the appropriate receptacle on the control module. The large 4-pin connector coming from the control module should be connected to the large 4-pin connector from the fused wire harness. The small 3-pin connector on the fused harness is used for the electronic engine kill module. There are 3 loose wires coming from the fused wire harness. The black (negative) and large red (positive) go directly to the battery; the small red is for switched 12v power. The small red lead can be connected to any 12v positive switched wire. Cut the small red wire to proper length and use blue quick tab connector provided or preferably solder this connection. The large red and black battery wires can also be cut to proper length, and then solder on the ring terminals provided. Attach the positive soldered ring terminal to the positive battery pole. Farther along in the installations the black wire will get connected to the negative battery pole.

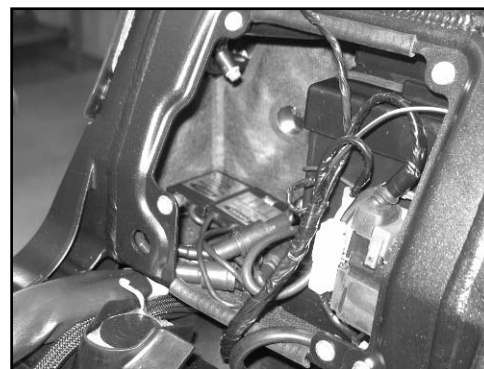

Figure 2

The electronic engine kill module is also mounted in the battery compartment with the control module. See instruction sheet included with the electronic engine kill module.

INSTALLATION OF ELECTRIC SHIFT CYLINDER:

Remove the rubber sleeve from the stock gear shift pedal. (WD-40 sprayed inside the sleeve will make removal easier) Slide the Pingel shift peg bracket over the stock gear shift pedal and orient it so the groove on the side, (A) in figure 3, lines up with the casting seam on the stock footpeg. The bracket must be placed exactly as shown or the shifter will not operate properly. The Pingel shift peg adapter has (8) set screws that must have thread locker applied and be tightened evenly. Install the stock rubber sleeve onto the Pingel shift peg bracket.

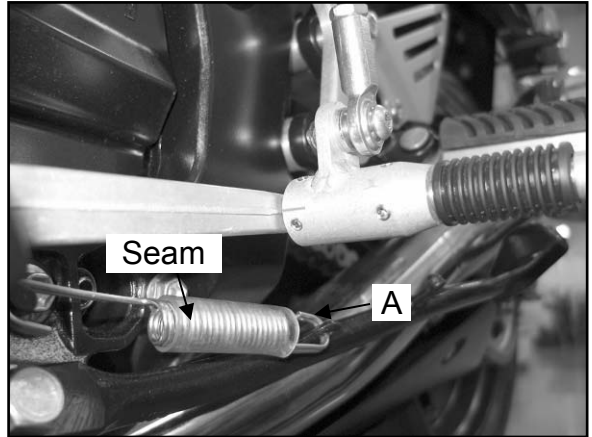

Figure 3

Remove the 2 bolts that hold the left foot peg bracket to frame, (A) in figure 4. Swing the foot peg bracket towards the outside of the motorcycle. Apply the supplied thread locker to the 8mm x 60mm socket head cap screws and insert them through the holes of the shift cylinder support bracket, the step bushings (with the smaller diameter towards the stock footpeg bracket), the holes of the stock footpeg brackets and the .540" thick aluminum spacers and tighten into the stock holes, see figure 5.

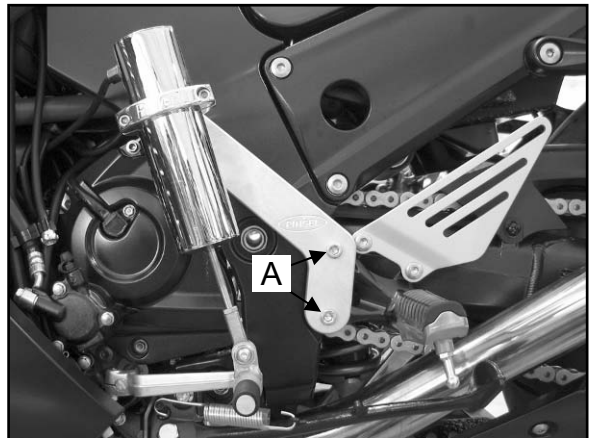

Figure 4

Install the electric shift cylinder onto the shift cylinder support bracket using the Pingel clamp and (2) 1/4-20 x 3/4" socket head cap screws. Tighten these screws and check rod end to shift lever alignment. Insert the 1/4-28 x 1" button head socket cap screw through the rod end of the electric shift cylinder, through the 1/4" flat washer(s) and the Pingel shift lever bracket. The rod end on the shift cylinder should be able to go past the point of mounting in each direction sideways. The point of mounting is that flat surface upon which the rod end bolts to the Pingel shift lever bracket allowing for the thin flat 1/4" washer(s) (used in the following steps) also. It is imperative that there is no side pressure or tension on the electric shift cylinder shaft when it meets its flat surface upon the Pingel shift arm lever where it is bolted as this would take away valuable power from the electric shift cylinder resulting in binding and missed shifts. If the rod end does not line up correctly you can either add 1 or more thin 1/4" flat washer(s) to the existing washer(s) to move the rod end away from the shift arm lever, or remove 1 or more thin flat 1/4" washer(s) to move the rod end closer to the shift arm lever. Note: (4) 1/4" flat washers are supplied to aid in alignment. Install the 1/4-28 locknut onto the 1/4"-28 x 1" BHSCS and tighten.

Before adjusting the shift cylinder up or down make sure the motorcycle shift lever is in its resting position. While holding onto the shift cylinder housing, loosen the two screws on the clamp. Find the groove in the center of the cylinder shaft, (A) in Figure 6. Adjust the cylinder housing up or down so the groove in the shaft is aligned with the plastic bushing located on the bottom of the cylinder housing, also shown in figure 6. With the shift cylinder in the correct position, tighten the two bolts of the Pingel clamp.

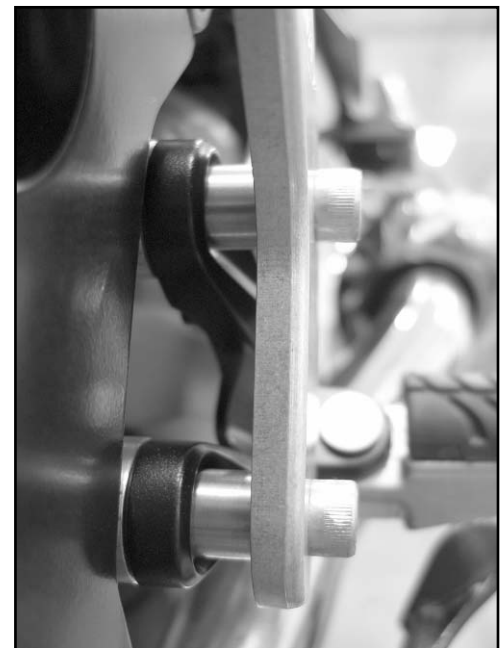

Figure 5

Route the electric cable from the electric shift cylinder to the control module located in the battery compartment. Attach the cable to the appropriate connector on the control module. Secure all wires away from heat and moving parts with the wire ties supplied.

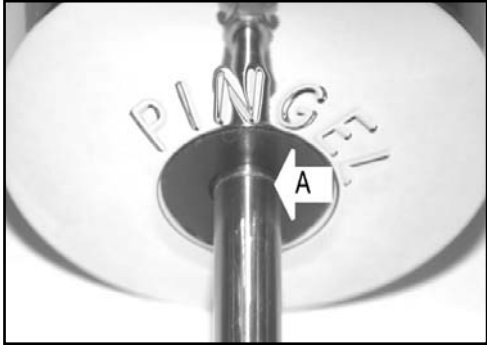

Figure 6

The Electric Speed Shifter kit installation should now be complete. Connect the negative battery cable and the negative wire from the electric shifter fused harness to the negative pole of the battery. Turn the ignition key on, pull in the clutch and push either button on the handlebar control and hold it for five seconds; this turns the control module on and must be done every time to activate the system. Check shifter movement by pushing either button on the handlebar control.

Test ride motorcycle. If shifting up or down is not achieved, you can loosen the Pingel clamp on the shift cylinder and adjust up or down 1/16" to 1/8" at one time. Retighten Pingel clamp and retest ride motorcycle. This adjustment is fastidious and patience is required. When you get final adjustment made, remove each clamp bolt and apply thread locker to the end threads, but remove only one clamp bolt at a time so as not to lose your adjustment.

Note: in the wire harness we have installed one 40-amp fuse for constant power. A spare 40-amp fuse is also supplied.

Prolonged repeated operation of the shifter (actuating the shifter repeatedly in rapid succession beyond normal use) can discharge the motorcycle battery and damage the shift cylinder and/or the control module. The normal battery takes 30-60 minutes to recharge after starting the motorcycle so use the shifter sparingly in this time.

Helpful Operating Tips:

Here is an example of what we found works for us: when upshifting at whatever your shift point RPM is (2000 – 6500) do not drop the RPM to make a shift happen, this will not help. RPM must be kept up to make a shift happen. When traveling at lower speeds, twist the throttle on slightly when hitting the shift button, to make a smoother shift. When downshifting, a slight crack of the throttle helps to smoothly go into lower gears, also if there is no load on transmission a simple push of the button should be sufficient. Our testing team has found that downshifting works best when shifting just under the following mph: 4th gear at 40mph, 3rd gear at 30mph, 2nd gear at 20mph and 1st gear at 10mph.

Note: Downshifting on a corner while leaning the bike may cause loss of control unless you use the clutch.

This unit is not waterproof. Do not subject it to pressure washing or extreme moisture.

Installation of the Electric Speed Shifter kit still maintains OEM Shifting.

If you have any questions please call 608-339-7999

Thank you for purchasing a Pingel Enterprise, Inc. product.



LIMITED WARRANTIES/LIABILITIES

Pingel Enterprise, Inc. assumes no responsibility or liability for damage or injury of any kind arising out of the use or misuse of any products. Pingel Enterprise, Inc.'s sole responsibilities with respect to products sold are to provide the following limited warranty:

Pingel Products: Pingel Enterprise, Inc. warrants to the original purchaser that the product shall be free from defects in parts and workmanship under normal use for 30 days from date of purchase. Pingel Enterprise, Inc.'s obligation under this warranty is limited to the repair or replacement of any part found to be defective when returned postpaid to the factory. The product must be returned with evidence of date and place of purchase, and detailed description of the problem. The warranty will not apply if the product has been installed incorrectly, repaired, or damaged by modification, misuse, negligence or accident. The repair or replacement of such part, as needed, is your sole and exclusive remedy. No refunds will be given. Pingel Enterprise, Inc. makes no other warranty, expressed or implied with respect to its products and specifically disclaims any implied warranties of merchantability or fitness of any product for a particular purpose and except as herewith stated assumes no liability with respect to the product.

Dispute Resolution: All disputes, claims or controversies of any kind that may arise between you and Pingel Enterprise, Inc. shall be brought in the state court located in Adams County, Wisconsin. You agree that the sole venue and jurisdiction for such disputes shall be the above named court and hereby submit to the jurisdiction of that court.

THANK YOU for purchasing a **PINGEL ENTERPRISE, INC.**, product. View our entire product line at www.pingelonline.com

Items Included: 2006-2012 Kawasaki ZX14 #77102

- 1 - Shifter lever bracket with set screws
- 1 - 1/4-28 x 1" BHSCS
- 1 - 1/4-28 locknut
- 4 - 1/4" washers
- 1 - Electric shift cylinder support bracket with cylinder clamp (threaded)
- 1 - Cylinder clamp (thru-holes)
- 2 - 8mm x 1.25mm x 60mm SHCS
- 2 - 1.00 o.d. x .315 i.d. x .540 long aluminum spacers
- 2 - special aluminum step spacers
- 1 - Electric shift cylinder
- 1 - Fused wiring harness
- 1 - 7/8" handlebar dual button control assembly
- 1 - Control module
- 2 - Hook & loop pieces
- 1 - Electronic engine kill module
- 1 - Electronic engine kill module wire leads
- 2 - Ring terminals
- 5 - Blue quick tab connector
- 10 - Wire ties
- 1 - Tube thread locker
- 1 - 40-amp fuse

Dear Valued Customer,

Pingel Enterprise, Inc. would like to take this opportunity to thank you for purchasing one of our Electric Speed Shifter Kits.

We would also like to know what you think of the product and how your installation went. Your assistance can help us overcome any technical issues that other installers may experience. You can reach us toll free at 1-888-474-6435 or email us at info@pingelonline.com.

We are also requesting photos of your installation. Your photos may be selected for publication in the Pingel catalog or at www.pingelonline.com. Photos may be submitted by emailing them to info@pingelonline.com. When submitting a photo, please include the motorcycle model and year.

Thank you again for your purchase!